

# 天线开关模块

RoHS指令对应产品

## Semi-Quad频带 GSM850/GSM900/DCS/PCS 用

ASM系列 ASM4518806T-2505

形状·尺寸

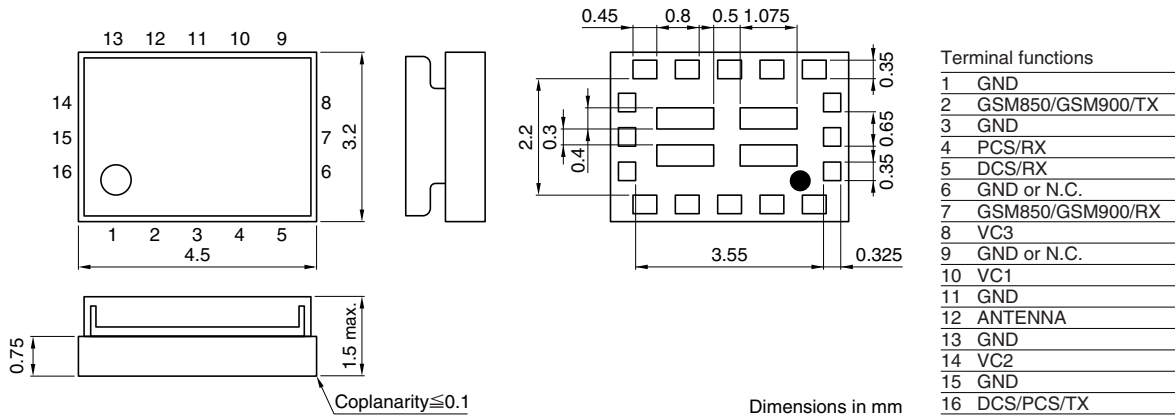

方块图

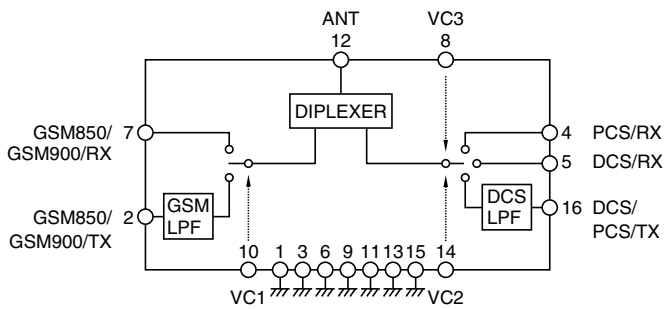

Logic

适用	VC1	VC2	VC3
GSM850/GSM900/TX	High	Low	Low
GSM850/GSM900/RX	Low	Low	Low
DCS/PCS/TX	Low	High	Low
DCS/RX	Low	Low	Low
PCS/RX	Low	Low	High

● RoHS 指令的对应：表示除了依据 EU Directive 2002/95/EC 免除的用途之外，未使用铅，镉，汞，六价铬及特定溴系难燃剂 PBB，PBD 等。

· 记载内容，在没有予告的情况下有可能改进和变更，请予以谅解。

## 电气特性

项目		单位	最小值	代表值	最大值	
GSM850 TX模式	插入损耗[824 to 849MHz]T=25°C	dB			1.2	
	插入损耗[824 to 849MHz]T=-30 to +85°C	dB			1.4	
	带内纹波	dB			0.25	
	衰减量	2f tx [1648 to 1698MHz]	dB	30		
	衰减量	3f tx [2472 to 2547MHz]	dB	30		
	隔离 GSM850/TX-GSM850/RX [824 to 849MHz]	dB		25		
	隔离 GSM850/TX-DCS/RX [824 to 849MHz]	dB		25		
	隔离 GSM850/TX-PCS/RX [824 to 849MHz]	dB		25		
	隔离 GSM850/TX-DCS/PCS/TX [824 to 849MHz]	dB		20		
	隔离 DCS/PCS/TX-ANT [1648 to 1698MHz]	dB		20		
	输入 VSWR TX					1.5
	输入 VSWR ANT					1.5
	高次谐波水平[at ANT]	2f tx [Pin=35dBm]	dBc			-70
		3f tx [Pin=35dBm]	dBc			-70
GSM850/RX模式	插入损耗[869 to 894MHz]T=25°C	dB			1.0	
	插入损耗[869 to 894MHz]T=-30 to +85°C	dB			1.2	
	带内纹波	dB			0.25	
	隔离 GSM850/TX-ANT [824 to 849MHz]	dB	20			
	输入 VSWR ANT					1.5
	输入 VSWR RX					1.5
GSM900 TX模式	插入损耗[880 to 915MHz]T=25°C	dB			1.2	
	插入损耗[880 to 915MHz]T=-30 to +85°C	dB			1.4	
	带内纹波	dB			0.25	
	衰减量	2f tx [1760 to 1830MHz]	dB	30		
	衰减量	3f tx [2640 to 2745MHz]	dB	30		
	隔离 GSM900/TX-GSM900/RX [880 to 915MHz]	dB		25		
	隔离 GSM900/TX-DCS/RX [880 to 915MHz]	dB		25		
	隔离 GSM900/TX-PCS/RX [880 to 915MHz]	dB		25		
	隔离 GSM900/TX-DCS/PCS/TX [880 to 915MHz]	dB		20		
	隔离 DCS/PCS/TX-ANT [1760 to 1830MHz]	dB		20		
	输入 VSWR TX					1.5
	输入 VSWR ANT					1.5
	高次谐波水平[at ANT]	2f tx [Pin=35dBm]	dBc			-70
		3f tx [Pin=35dBm]	dBc			-70
GSM900/RX模式	插入损耗[925 to 960MHz]T=25°C	dB			1.0	
	插入损耗[925 to 960MHz]T=-30 to +85°C	dB			1.2	
	带内纹波	dB			0.25	
	隔离 EGSM850/TX-ANT [880 to 915MHz]	dB	20			
	输入 VSWR ANT					1.5
	输入 VSWR RX					1.5
DCS/TX模式	插入损耗[1710 to 1785MHz]T=25°C	dB			1.5	
	插入损耗[1710 to 1785MHz]T=-30 to +85°C	dB			1.7	
	带内纹波	dB			0.25	
	衰减量	2f tx [3420 to 3570MHz]	dB	30		
	衰减量	3f tx [5130 to 5355MHz]	dB	30		
	隔离 DCS/PCS/TX-GSM/RX	[1710 to 1785MHz]	dB	22		
	隔离 DCS/PCS/TX-DCS/RX	[1710 to 1785MHz]	dB	22		
	隔离 DCS/PCS/TX-PCS/RX	[1850 to 1890MHz]	dB	30		
	隔离 DCS/PCS/TX-PCS/RX	[1710 to 1785MHz]	dB	22		
	隔离 DCS/PCS/TX-GSM/TX	[1710 to 1785MHz]	dB	20		
	输入 VSWR TX					1.5
	输入 VSWR ANT					1.5
	高次谐波水平[at ANT]	2f tx [Pin=32dBm]	dBc			-67
		3f tx [Pin=32dBm]	dBc			-67
DCS/RX模式	插入损耗[1805 to 1880MHz]T=25°C	dB			1.4	
	插入损耗[1805 to 1880MHz]T=-30 to +85°C	dB			1.6	
	带内纹波	dB			0.25	
	隔离 DCS/PCS/TX-ANT [1710 to 1785MHz]	dB	20			
	输入 VSWR ANT					1.5
	输入 VSWR RX					1.5

## 电气特性

项目		单位	最小值	代表值	最大值	
PCS/TX 模式	插入损耗[1850 to 1910MHz]T=25°C	dB			1.5	
	插入损耗[1850 to 1910MHz]T=-30 to +85°C	dB			1.7	
	带内纹波	dB			0.25	
	衰减量	2f <sub>tx</sub> [3700 to 3820MHz]	dB	30		
	衰减量	3f <sub>tx</sub> [5550 to 5730MHz]	dB	30		
	隔离 DCS/PCS/TX-GSM/RX	[1850 to 1910MHz]	dB	22		
	隔离 DCS/PCS/TX-DCS/RX	[1850 to 1910MHz]	dB	22		
	隔离 DCS/PCS/TX-DCS/RX	[1850 to 1910MHz]	dB	22		
	隔离 DCS/PCS/TX-GSM/TX	[1850 to 1910MHz]	dB	20		
	输入 VSWR TX					1.5
	输入 VSWR ANT					1.5
	高次谐波水平[at ANT]	2f <sub>tx</sub> [Pin=32dBm]	dBc			-67
		3f <sub>tx</sub> [Pin=32dBm]	dBc			-67
	PCS/RX 模式	插入损耗[1930 to 1990MHz]T=25°C	dB			1.4
插入损耗[1930 to 1990MHz]T=-30 to +85°C		dB			1.6	
带内纹波		dB			0.25	
隔离 DCS/PCS/TX-ANT [1710 to 1910MHz]		dB	20			
输入 VSWR ANT						1.8
输入 VSWR RX						1.8
VC1, VC2, VC3	High	V	2.5	2.6	2.7	
	Low	V	0	0	0.2	
消耗电流	TX 模式	mA		6	10	
	EGSM/DCS RX 模式	mA			5	
	PCS RX 模式	mA		1.5	2	
温度范围	工作时	°C	-30		+85	
	保存时	°C	-40		+95	

## 测定电路

